



Stenhøj Maestro H.32

2-post electro-hydraulic lifts

Maestro H.32 lifts are especially suitable for all kinds of repairs that require free access to underbody and wheels. The Maestro H.32 has a lifting capacity of 3.2 t.

Features:

Top safety:

- emergency stop valve
- fail-safe equalizer system
- automatic arm lock system
- automatic air-operated parking system

Elegant control box

- 3 pushbuttons – up, down and parking
- placed in comfortable working height

Arms can be parallel-parked

- advantage when having to lift vehicles with very short wheel base
- easy and quick positioning of arms to lifting points of vehicle

Lifting height

- S-models: 2050 mm
- C-models: 2240 mm



STENHØJ

DK-7150 Barrit

Phone: +45 7682 1330

Fax: +45 7682 1331

www.stenhøj.dk

E-mail: autolift@stenhoj.dk

Stenhøj Maestro H.32

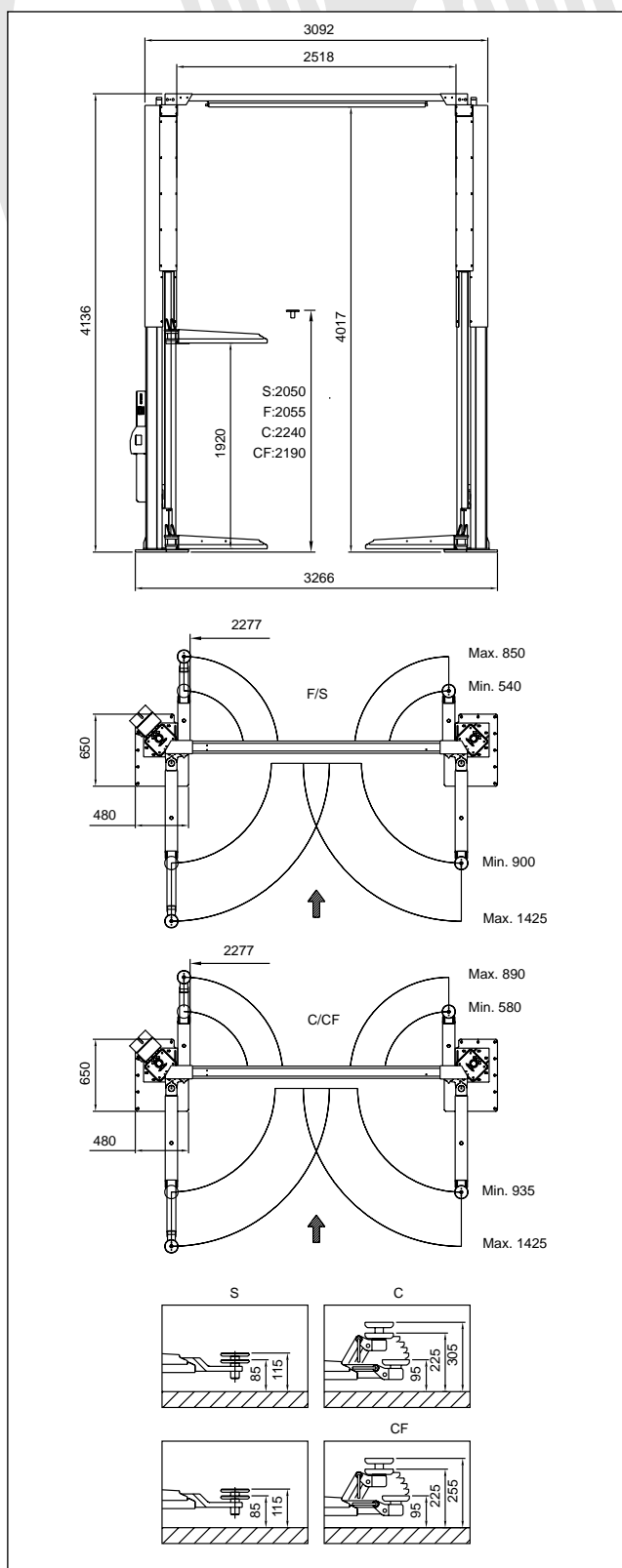

Technical data:

| | |
|---------------------|----------|
| Lifting capacity: | 3200 kg |
| Lifting time: | 22 sec. |
| Motor: | 3.0 kW |
| Min./max. pressure: | 5/10 bar |

Maestro H.32

Optional extras for all models:

Expansion bolts, tool trays, switch outlet, a large program of special pads developed in cooperation with leading car manufacturers

Optional extras, F- & CF-models only:

ø120 flex pad (30-60 mm), ø160 mm flex pad (90-150 mm), ø160 flex pad (150-255 mm), 100 mm flex pad (ø120), 190 mm flex pad (ø120), 260 mm flex pad (ø120), 100 mm U-pad, 190 mm U-pad, 260 mm U-pad.

Optional extras, S-models only:

100 mm, 190 mm and 260 mm pad sets.

Corrosion-proof surface treatment

All Stenhøj lifts are led through a sling purifying plant (according to SA2.50 - ISO-Norm 8501-1:1988), dipped in primer, and finally led through an electro-static powder bake plant.

Standard colours:

Red RAL 3013
White RAL 9002.
Special colour combinations on request.

Identification of a Maestro H.32 lift:

First letter (H) = hydraulic lift
Last two digits (32) = capacity in 100 kg
Letters:

S = screw pad
F = flex pad
C = combi pad
CF = combiflex pad

No liability accepted for specifications, which are subject to alteration.



STENHØJ

DK-7150 Barrit

Phone: +45 7682 1330

Fax: +45 7682 1331

www.stenhøj.dk

E-mail: autolift@stenhøj.dk